

Masted  
trucks

■ **MC 30 T**

## A reliable, productive yard truck

- Capacity 3000 kg
- Lifting height 3 m to 7 m
- 2 wheel drive
- Motorization Turbo Euro III



\* Model presented with its options.

 **MANITOU**

# MC 30: A reliable, productive yard truck

*Specially designed for outdoor handling applications, the MC 30 T makes managing your storage area easier. Handle and store with full peace of mind and easily handle and store loads up to 3 tons, even on unconsolidated ground.*



## • The MANITOU solution for outdoor handling

Ideal for loading lorries and storage yards, the MC 30 T makes the operator's life simpler, due to its distinctive features: a wide track for improved stability, a high ground clearance for travelling over kerbs or other obstacles, full visibility, rugged mast for safety, quick and safe cab access, ergonomic controls for improved manoeuvrability, and high travelling speed (24 km/h) for higher efficiency. In addition, because of the stability of the MC 30 T, the operator can safely access the most unstable areas of the site and quickly put the load into place.

## • The experience of versatile handling

Already widely acclaimed for its unmatched performance, the MC 30 T is suited to any kind of handling: in narrow alleys, it proves outstandingly manoeuvrable due to its short turning radius; for storage at a height, it can be fitted with up to 7-metre masts; it has a hydraulic differential lock as standard which allows it to travel through difficult areas.



The MC 30 T is indispensable, whatever your activity.

## • The assurance of rugged design

The MC 30 T, and the MC range in general, is the result of continuous interaction between MANITOU's design office and the users. The components have been designed for use in the most arduous conditions

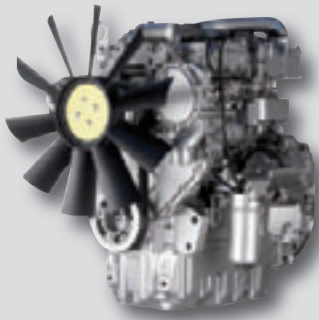

The Perkins 1104 D 44 Turbo – 4-cylinder direct-injection engine has been chosen for its performance and reliability. It develops 95 hp/70 kW at the rated speed of 2200 rpm and conforms to the Euro III standard. In addition, the MC 30 T is fitted with a torque converter transmission and a 4-ratio gearbox, so that the user can choose between driveability or speed of travel, depending on working conditions.

## • The value of easy maintenance

As maintenance is part of the life of a handling truck, the operator has full access to the engine for easy inspection and maintenance. The quality of design of the MC 30 T minimizes the risk of downtime, extends the lifetime of the truck, and reduces maintenance costs.







**The MC range includes models from 3 to 7 tons.**

## MC 30 T Roller masts

MASTS		LIFTING HEIGHT ON FORKS (mm)	OVERALL HEIGHT MAST LOWERED (mm)	FREE LIFT ON FORKS (mm)	OVERALL HEIGHT MAST EXTENDED (mm)	HEIGHT AT MAX. CAPACITY (mm)		CAPACITY AT MAX. HEIGHT (kg)		MAST TILTING ANGLE Front/Rear
						With side shift carriage	Without side shift carriage	With side shift carriage	Without side shift carriage	
DUPLEX TOTAL VISIBILITY	3.00 m	3030	2460	130	4045	3000		3000	3000	6°/12°
	3.30 m	3330	2460	130	4345	3300		3000	3000	6°/12°
	3.70 m	3730	2715	130	4745	3700		3000	3000	6°/12°
	4.00 m	4030	2905	130	5045	4000		3000	3000	6°/12°
	4.50 m	4530	3155	130	5545	4000		2800	2900	6°/12°
	5.00 m	5030	3405	130	6045	4000		2400	2600	6°/12°
DUPLEX FREE LIFT	3.00 m	3040	2305	1383	3962	3000		3000	3000	6°/12°
	3.30 m	3340	2455	1533	4262	3300		3000	3000	6°/12°
	3.50 m	3540	2555	1633	4462	3500		3000	3000	6°/12°
	3.70 m	3740	2715	1793	4662	3700		3000	3000	6°/12°
	4.00 m	4040	2905	1983	4962	4000		3000	3000	6°/12°
TRIPLEX TOTAL VISIBILITY	5.50 m Without Free lift	5545	2985	-	6655	4000		1900	2100	6°/10°
TRIPLEX FREE LIFT	3.70 m	3740	2460	1283	4662	3700		3000	3000	6°/12°
	4.00 m	4040	2460	1383	4962	4000		3000	3000	6°/12°
	4.30 m	4340	2460	1533	5262	4000		2900	3000	6°/12°
	4.70 m	4740	2555	1633	5662	4000		2600	2800	6°/12°
	5.00 m	5040	2715	1793	5962	4000		2400	2600	6°/12°
	5.50 m	5540	2905	1983	6462	4000		1900	2100	6°/12°
	6.00 m	6040	3155	2233	6962	4000		1600	1800	6°/12°
	6.50 m	6540	3405	2483	7462	4000		1200	1350	6°/12°
	7.00 m	7040	3655	2733	7962	4000		900	1000	6°/12°

## MC 30 T Tyres

Standard		Option		
Front	Rear	Front	Rear	Rear
Mixed	Industrial	Farming	Industrial	Industrial
14,5 R 20 MPT 80 Tubeless 18 PR - 143 G/J	10 R 17.5 134/132 M G291	380/75 R 20 XMCL	10 R 17.5 LDR Tubeless 134/132 L	10 R 17.5 LSR Tubeless 134/132 L
Tyre width (mm)				
350	250	385	262	262
Overall width (mm)				
1900	1815	1935	1827	1827
				

# MC 30 T with roller mast load chart

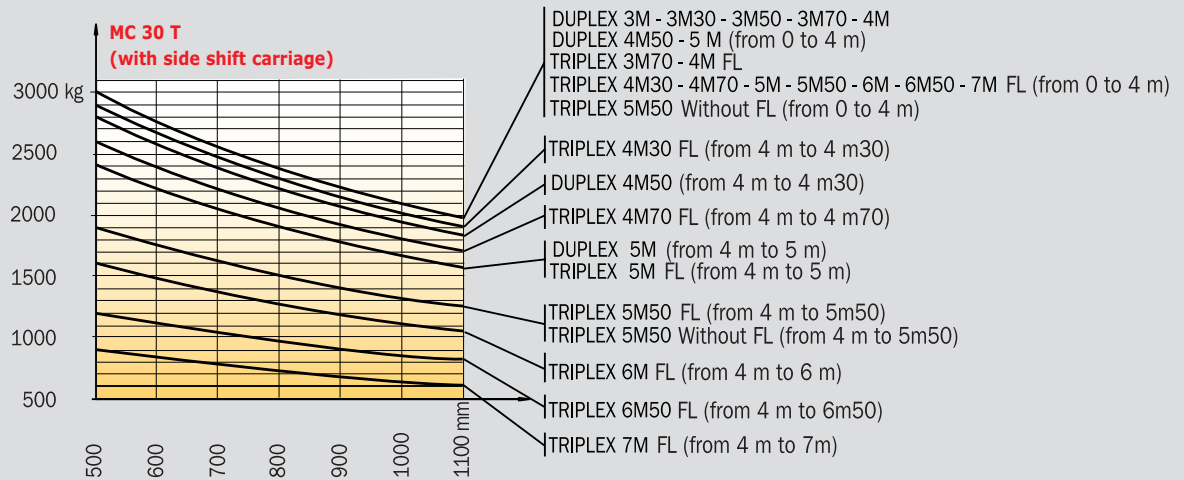
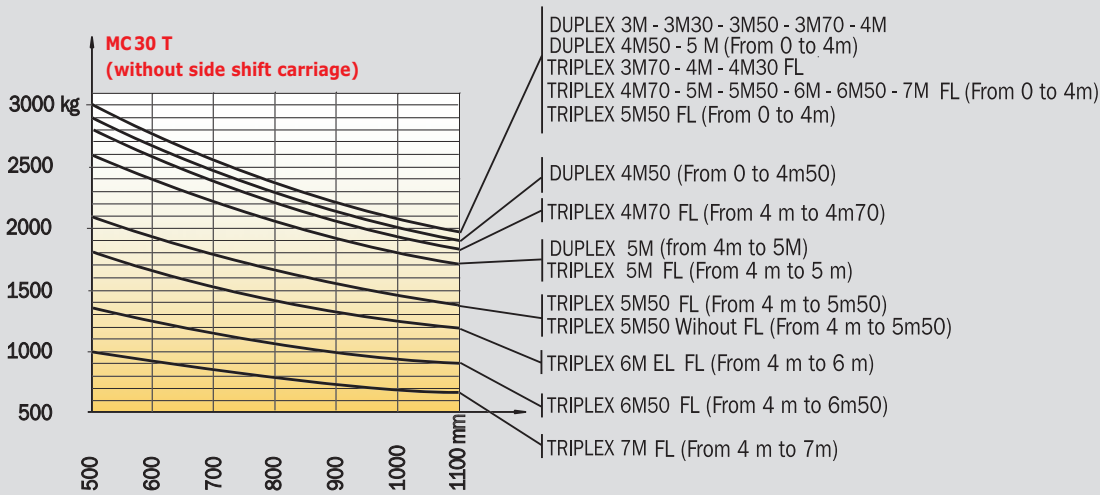

## Equipment

### STANDARD EQUIPMENT

- Carriage 1470 mm (FEM III)
- Driver protection
  - Tinted windscreen and rear window
  - Front and rear wipers
  - Front windscreen washer
  - Skai seat
  - Safety belt
- Load shock absorber
- Driver presence detection

### OTHER OPTIONAL EQUIPMENT

#### Mast and accessories :

- Wide choice of forks
- Different carriage sizes
- Load back rest
- Hydraulic outlets for accessories
- Quick-release couplings
- Side-shift carriage
- Fork positioners
- Agricultural bucket
- Rehandling, earth moving or concrete bucket

#### Cab and driver comfort :

- Complete cab with side doors
  - Tinted windscreen and rear window
  - Front and rear wipers
  - Front windscreen washer
  - Skai seat
  - Safety belt
  - Heating
- Air-conditioning
- More comfortable seat (fabric or pneumatic)
- Sliding door bay
- Roof wiper
- Sun visor on roof window and windscreen
- Document holder
- Car radio
- Tilttable steering column

#### Safety :

- Rotating lamp
- Road lighting adjustment
- Internal and external rear-view mirror adjustment
- Working lights (front or rear)

- Back-up alarm buzzer
- Balancing valve on tilt cylinders
- Foam inflation
- Emergency circuit-breaker
- Battery cut-off switch
- Anti-theft systems

#### Difficult environment and medium :

- Differential lock
- Wide choice of tyres (multipurpose, all terrain...)
- Wing extensions
- Cyclonic or self-cleaning prefilter
- Prefilter heightener

#### Cold countries :

- Diesel heater
- Battery for cold conditions

#### Special offers (some examples):

- Specific accessory
- Spark-guard

...

# MC 30 T

 **Load capacity** .....3000 kg  
At 500 mm load center

 **Standard lifting height** .....3,70 m  
Speed unladen/laden (m/s)  
Lifting .....0,6/0,5  
Lowering .....0,5/0,5

 **Tyres**  
Front.....14,5 R 20 MPT 80  
Tubeless 18 PR 143 G/J  
Rear .....10 R 17,5 134/132 M G 291

 **Forks (mm)**  
Length.....1200  
Width x thickness .....125x40

 **Brakes hydraulically operated oil-immersed multidiscs**

 **PERKINS engine Euro III**  
Type .....1104 D 44 T  
Capacity.....4 cyl. 4400 cm<sup>3</sup>  
Rated speed .....2200 tr/mn  
Power at 2300 t/mn.....70 kW (95 hp)  
(ISO/TR 14396)  
Maximum torque.....302 Nm at 1400 tr/mn  
Direct injection  
Water cooling  
Travelling up a slope when unloaded .....27%  
Travelling up a slope when loaded .....58%

 **Transmission** .....Torque convertor  
Electro hydraulic reversing shift  
4 speeds forward and reverse  
Maximum travel speed .....24 km/h  
Hydraulic differential lock

 **Hydraulics**  
Main pump  
Gear type .....185 bar/85 l./mn  
Flow divider with priority to steering  
gear type .....125 bar/85 l./mn

 **Capacities**  
Cooling system .....14,5 l  
Engine oil .....8,5 l  
Hydraulic oil.....64 l  
Transmission oil .....15,5 l  
Fuel tank .....85 l

 **Weight (with mast and forks)** .....5090 kg

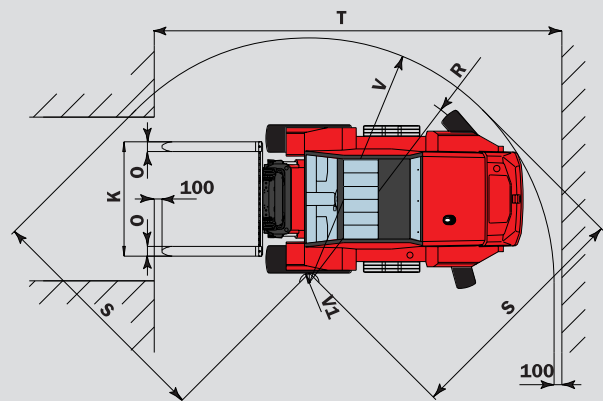
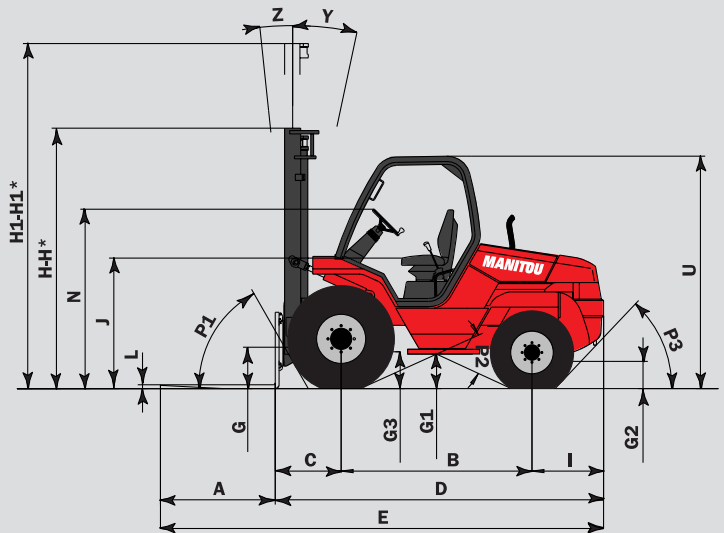

	Roller mast
A	1200
B	1995
C	697
D	3442
E	4642
F	1550
F1	1524
G	425
G1	385
G2	300
G3	380
H	2715
H1	4745
H*	2205
H1*	4662
I	750
J	1400
K	1470
L	40
N	1880
O	125
P1	60,5°
P2	49°
P3	46,5°
R	2910
S	3060
T	5307
U	2460
V	3210
V1	300
W	1900
Y	12°
Z	6°

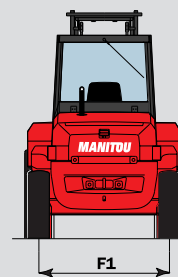

This equipment described in this leaflet may be standard, optional, or unavailable, depending on the versions. For more details, contact your MANITOU dealer.

# Manitou, material handling world leader

Inventor of the rough terrain forklift truck, Manitou offers today the most comprehensive range to meet all specific handling and personal lifting requirements :

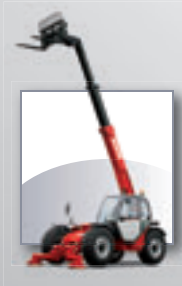

**MANISCOPIC**  
Telescopic trucks



**MANITOU**  
Rough terrain and semi industrial masted trucks

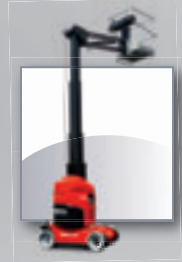

**MANIACCESS**  
Access equipment



**Twisco**  
Compact telescopic handler



**MANIHOE**  
Backhoe/Loader with telescopic boom



**MANITRANSIT**  
Truck mounted forklifts



**MANILOADER**  
Articulated wheeled loaders



**MANILEC**  
Electric pallet trucks and electric stackers

## A network of skilled professionals at your service !

With a network of 600 service and parts centres in more than 120 countries, Manitou provides an efficient after-sales support based on the expertise of thousands of factory trained technicians.



The equipment supplied with each model may differ from that described in this leaflet. For more details, contact your MANITOU dealer.