

MANISCOPIC

MRT 3050 PRIVILEGE

- Lift height : 29.70 m
- Max. reach : 25.50 m
- Engine : 216 HP – 159 kW
- 4 wheel drive and steering
- Hydrostatic transmission with a powershift gearbox
- Suspended chassis



 **MANITOU**

ROTATION ON STABILIZERS FULLY EXTENDED WITH FORKS 360°

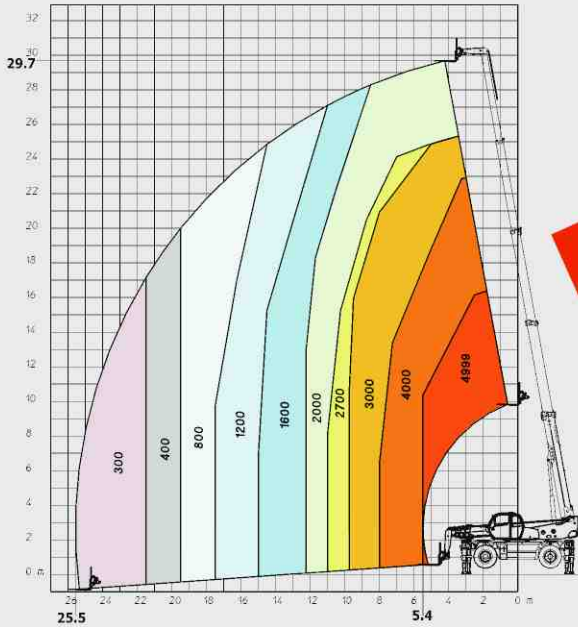

HANDLING

FRONTAL POSITION ON WHEELS WITH FORKS

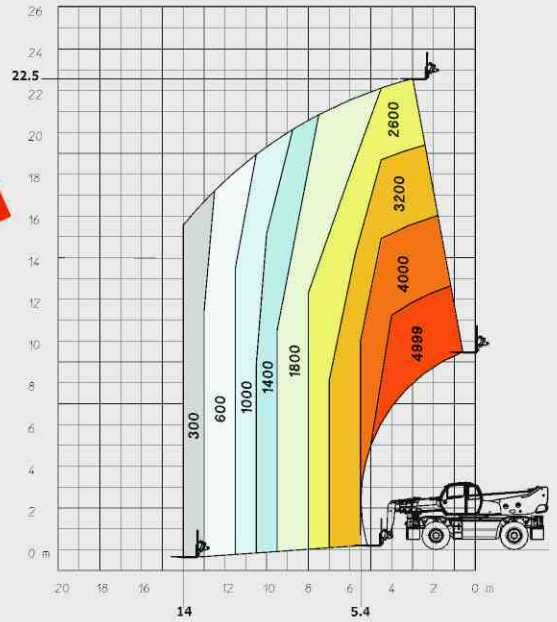

ROTATION ON STABILIZERS FULLY EXTENDED WITH 365 KG ORH PLATFORM - 2.25/4 M

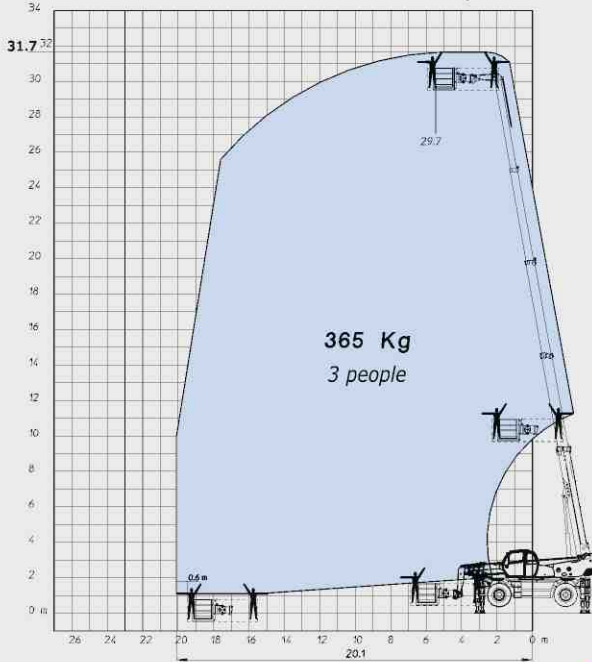

ROTATION ON STABILIZERS FULLY EXTENDED WITH 1000 KG PLATFORM 2,25/4 M



ROTATION ON STABILIZERS FULLY EXTENDED WITH AERIAL JIB 1 PLATFORM

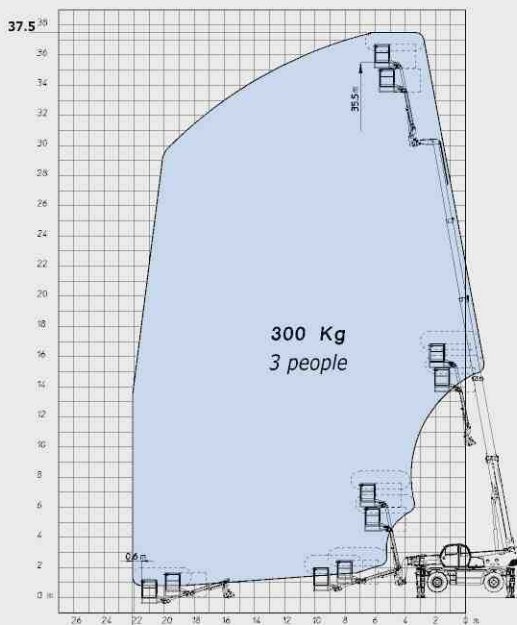

PERSONNEL LIFT

ROTATION ON STABILIZERS FULLY EXTENDED WITH 3D SWING ARM IN POSITIVE POSITION

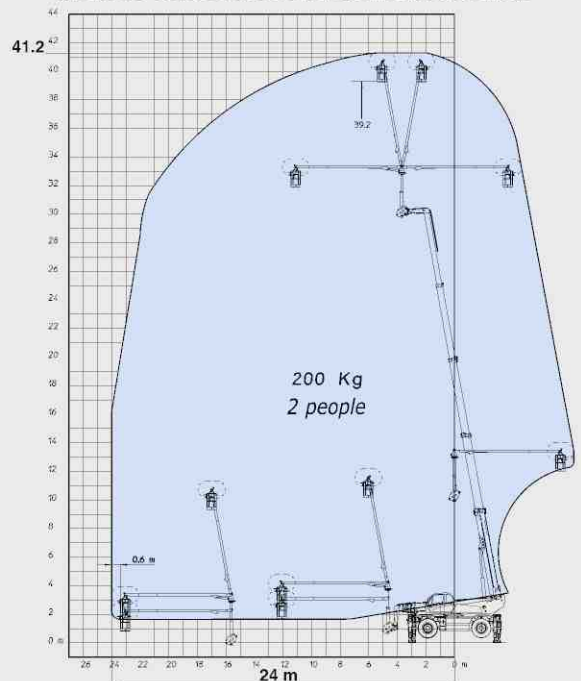

POSSIBILITY TO WORK IN THE NEGATIVE POSITION

PRIVILEGE

MRT 3050

ROTATION ON STABILIZERS FULLY EXTENDED WITH TELESCOPED PT 800 JIB

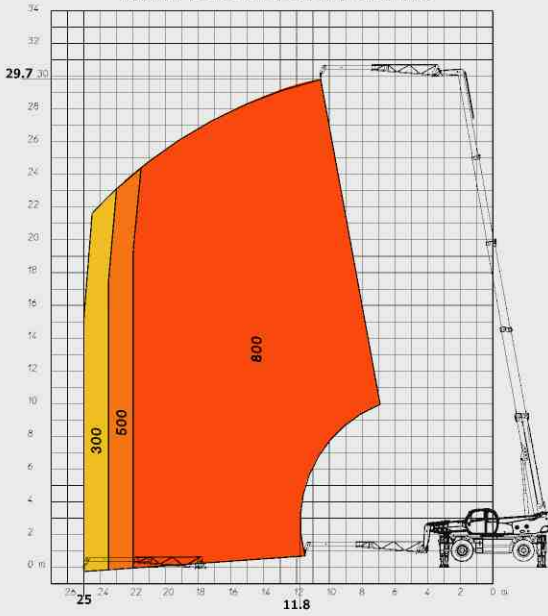

ROTATION ON STABILIZERS FULLY EXTENDED WITH 1500 KG JIB

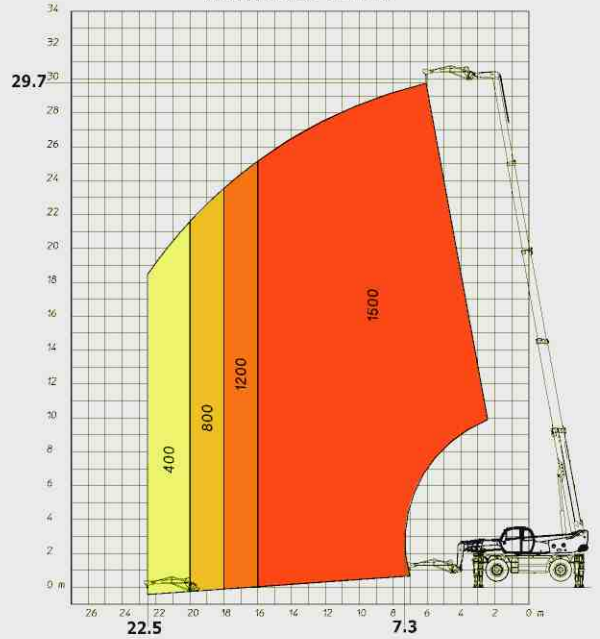

ROTATION ON STABILIZERS FULLY EXTENDED WITH 3 T WINCH

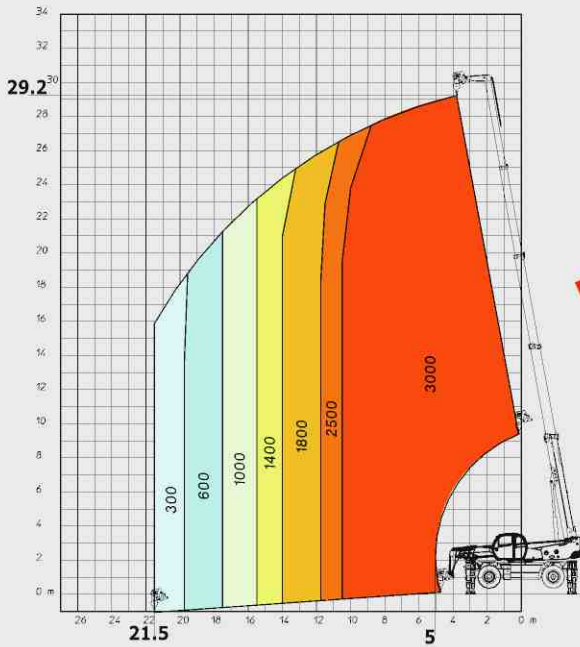

ROTATION ON STABILIZERS FULLY EXTENDED WITH 5 T WINCH

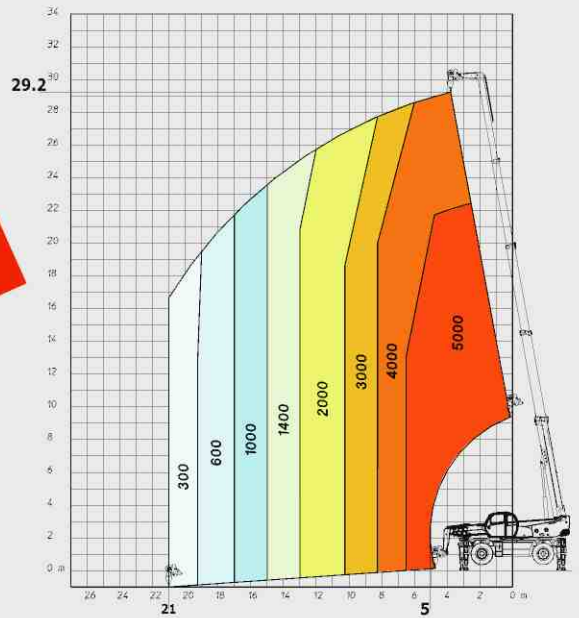

LIFTING

ROTATION ON STABILIZERS FULLY EXTENDED WITH 12 T WINCH

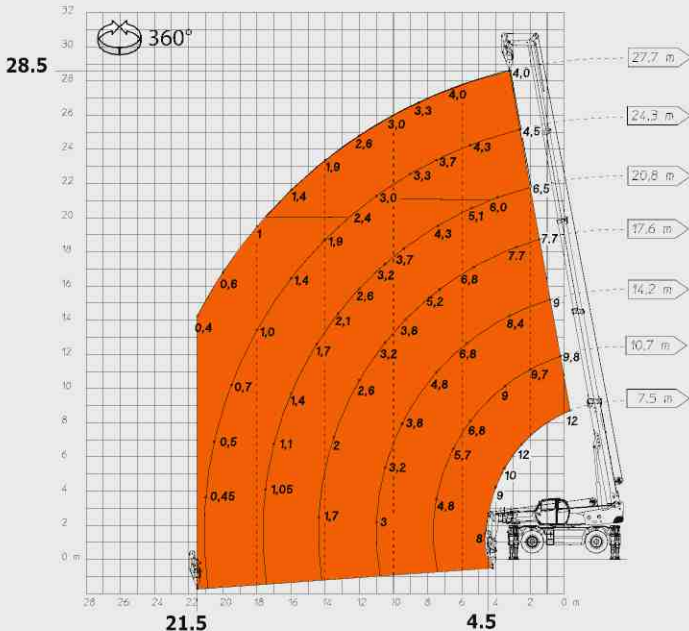

Lifting capacity	6 t	12 t
Sheaves	1	2
Lines	2	4
Rope diameter	14 mm	14 mm
Rope length	120 m	120 m
Max line pull	36.3 kN	36.3 kN
Available hook path at maximum boom extension	40 m	20 m
Available hook path at maximum boom retraction	50 m	25 m

MRT 3050 *PRIVILEGE*

-  **Lift capacity**4999 kg
at 500 mm from fork heels
-  **Lift height** (on stabilizers).....29.70 m
-  **Tyres**
17.5 R 25
-  **Forks** (mm)
Length.....1200
Width x thickness.....150 X 50
-  **Oil-bath multidisc brakes** hydraulically assisted
on both axles
Negative parking brake
-  **PERKINS Engine**
Type.....1106DE66TA - Euro3
Capacity.....6 cyl. 6600 cm³
Power (ISO/TR 14396)216 HP/159 kW
932 Nm at 1400 rpm
Water cooling
Common-rail injection
-  **Power-regulated hydrostatic transmission**
with a powershift gearbox
(hydraulic variable-displacement pump
and variable-capacity hydrostatic motor)
Reversing shiftelectromagnetic
Gearboxpowershift
Travel speed40 km/h*
* this speed may be limited by local regulations
-  **Electronically controlled hydropneumatic suspension**
Lateral (8°) and longitudinal (3°)
Oscillating rear axle with automatic hydraulic lock
when rotated (>15°)
-  **4 triplex telescopic stabilizers**
simultaneously or individually controlled
-  **Total and continuous rotation**
Turret mounted on a double slew ring
Hydraulic swivel joint
Electrical rotating connector
-  **Hydraulics**
piston pump:
variable displacement (Load Sensing)....270 bars/165 l/min
gear pump.....220 bars/74 l/min
-  **Controls:** 2 electro-hydraulic proportional control
joysticks for all hydraulic movements
-  **Capacities**
Cooling system.....26 l.
Engine oil.....15.5 l.
Hydraulic oil285 l.
Fuel tank310 l.
-  **Weight unladen** (with forks)22860 kg
Overall width.....2.50 m
Overall height3.26 m
Overall length (without forks).....8.10 m
Ground clearance0.42 m
Drawbar pull.....10500 daN
-  **Standard load moment indicator**
(mobile crane standards)

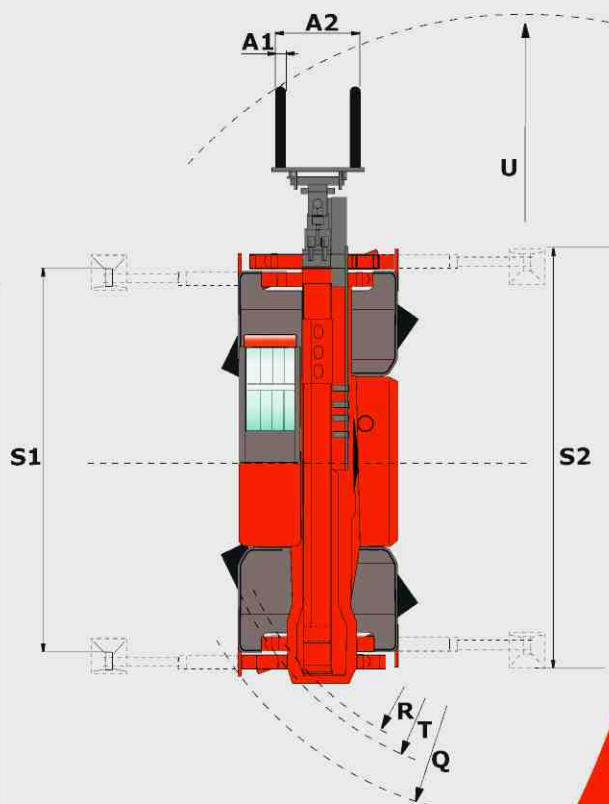
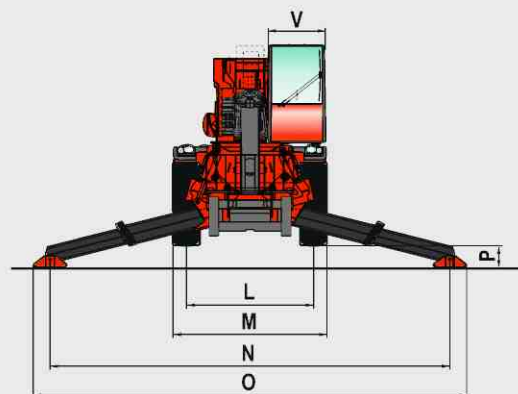
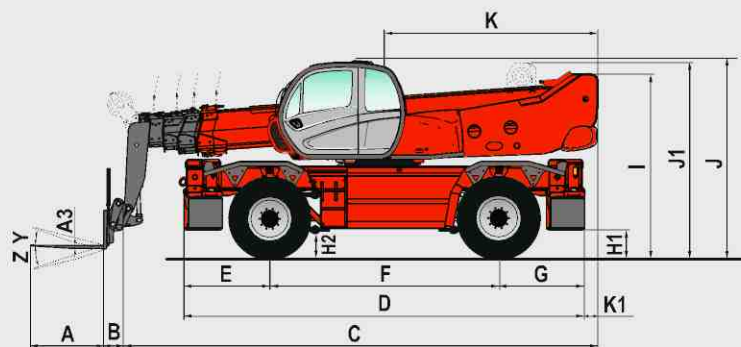

A	1200
A1	150
A2	1320
A3	50
B	320
C	7783
D	6787
E	1409
F	3750
G	1628
H1*	480
H2*	420
I*	3035
J*	3180
J1*	3160
K	3500
K1	218
L	2060
M	2498
N	6490
O	7100
P*	350
Q	5560
R	4690
S1	5945
S2	6490
T	4910
U	7000
V	923
Y	12°
Z	105°

mm
*Measured at suspension
mid point ±78 mm



The specifications contained herein shall not bind the manufacturer and are subject to change without notice.
The equipment described in this brochure can be standard, optional or unavailable, depending on the versions.
For more details, contact your MANITOU dealer.